

DRAWING IS PRODUCED USING THE IRISH TRANSVERSE MERCATOR (ITM) GEOGRAPHIC COORDINATE SYSTEM

A1

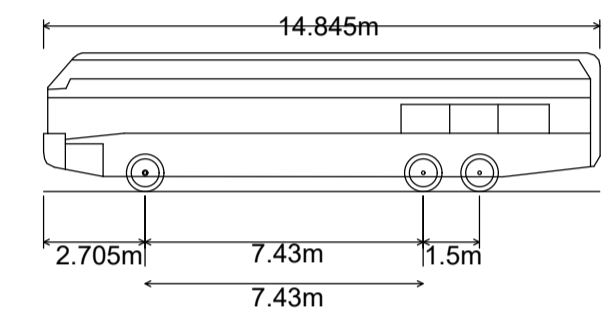

**Tionscald Éireann
Project Ireland
2040**



P&R COACH (VDL-FHD2-148)	14.845m
OVERALL LENGTH	14.845m
OVERALL WIDTH	2.550m
OVERALL BODY HEIGHT	3.700m
MIN BODY GROUND CLEARANCE	0.397m
TRACK WIDTH	2.500m
LOCK-TO-LOCK TIME	5.00s
CURB TO CURB TURNING RADIUS	12.500m

AUTOTRACK (LARGE COACH)
NOT TO SCALE

LEGEND:

- SITE EXTENTS —
- P&R COACH AUTOTRACK ANALYSIS —

P02	ISSUED FOR PLANNING	SM	BD	28/07/23
Rev	Description	Drawn	Checked	Date

Clifton Scannell Emerson Associates

Clifton Scannell Emerson Associates Limited
Consulting Engineers,
3rd Floor The Highline,
Bakers Point, Pottery Road,
Dun Laoghaire, Co. Dublin,
Ireland, A96 KW29

T. +353 1 288 5006
F. +353 1 283 3406
E. info@csea.ie
W. www.csea.ie

Client	WICKLOW COUNTY COUNCIL					
Project	FASSAROE PARK AND RIDE FACILITY AUTOTRACK LAYOUT (LARGE COACH)					
Dwg. Title						
Drawn By	SM					
Date	JULY 2023					
Checked By	BD					
Scale	1:500 @ A1					
CSEA Job No.	20_008N					
Project Code	Originator	Zone/Phase	Level	Type	Role	Dwg. No.
20_008N	CSE	GEN	XX	DR	C	3810
S2	PART VIII APPROVAL					
Status Code	Suitability Description					
P02	FOR PLANNING					
Revision	Project Status					